

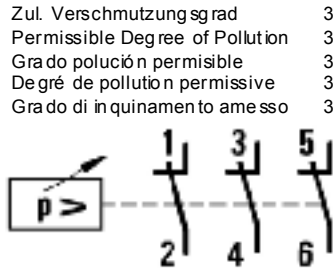

Max. zul. Motorleistung / Max. Motor Performance / Max. Potencia Admisible del motor / Puissance max. du moteur / Pot. max. ammissibile dei motori

U <sub>e</sub> ( 50 / 60 Hz)	3 ( AC-3 )	1 ( AC-3 )
120V	3,0 kW	1,1 kW
230 V	5,5 kW	2,2 kW
400 V	7,5 kW ( 11 kW )*	-
500 V	7,5 kW ( 11 kW )*	-
690 V	7.5 kW ( 15 kW )*	-

\*= mit SK 3 H, SK-R3 H - with SK 3 H, SK-R3 H - con SK 3 H, SK-R3 H avec 5K 3 H, SK-R3 H - con SK 3 H. SK-R3 H



Zul. Verschmutzungsgrad 3  
Permissible Degree of Pollution 3  
Grado polución permisible 3  
Degré de pollution permmissive 3  
Grado di inquinamento amesso 3

SCHALTBILD / WIRING DIAGRAM / ESQUEMA DE CONEXION / SCHEMA DE RACCORDEMENT / SCHEMA ELETTRICO

3-PHASIG / 3-PHASE / TRIFASICO  
/ TRIPHASE / TRIFASE

1-PHASIG / 1-PHASE / MONOFASICO / MONOPHASE / MONOFASE

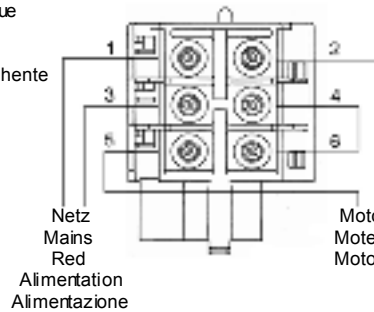
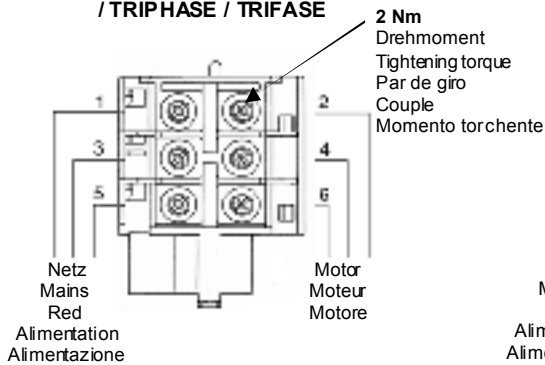

SK-....

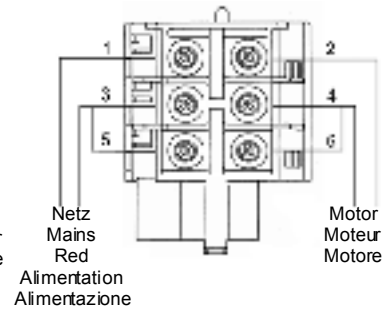

SK-R3/30/2

### ACHTUNG:

Vor der Druckeinstellung ist der Druckschalter freizuschalten. Die Druckeinstellung ist nur am montiertem Druckschalter bei unter Druck stehendem Gerät möglich.

### ATTENTION:

Adjustments are to be carried out only when the switch is mounted, under pressure and voltage-free.

### ATENCIÓN:

Cambios de presión deberán ser efectuados solo con el presóstato montado, bajo presión y libre de tensión.

### ATTENTION:

Le réglage de pression ne peut se faire que lorsque l'appareil est monté, sous pression et libre de tension.

### ATTENZIONE:

La regolazione va effettuata solo col pressostato montato, sotto pressione e disinserito.

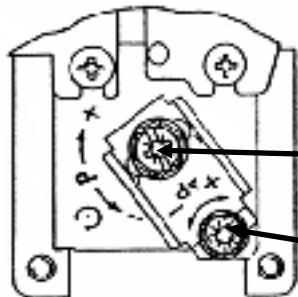

### Druckeinstellung / Pressure setting / Ajuste de presión / Réglage de la pression / Regolazione della pressione

Oberer Druckwert / Upper Pressure Setting / Presion de Disparo Superior / Pression Supérieure / Pression di Distacco

Druckdifferenz / Pressure Differential / Diferencial de Presión / Différentiel de Pression / Differenziale di Pressione

Einbau und Anschluß nur durch Fachkraft; nach Anbringung von Zubehör Funktionsüberprüfung durch Elektrofachkraft erforderlich.

Installation and assembly of electrical equipment shall be carried out by qualified personnel only.

Instalación y ensamblaje de equipos eléctricos deberán ser efectuados solamente por personal cualificado.

L'installation et raccordement des appareils doit être effectué par du personnel qualifié.

L'installazione e l'assemblaggio delle parti elettriche vanno eseguite esclusivamente da personale qualificato.

**DRUCKDIAGRAMME / PRESSURE DIAGRAMS / DIAGRAMAS DE REGULACION /  
DIAGRAMMES DE REGLAGE / DIAGRAMMI TARATURE**

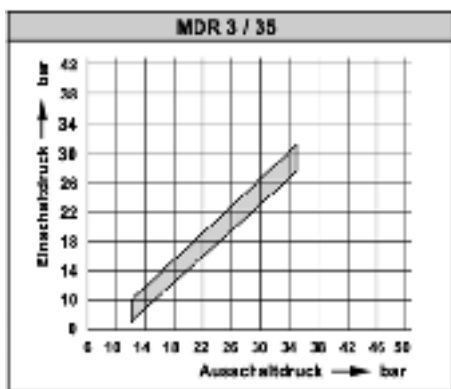
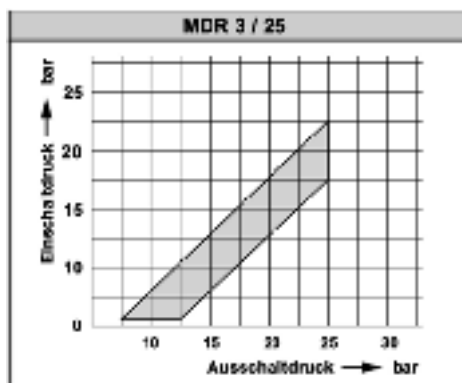
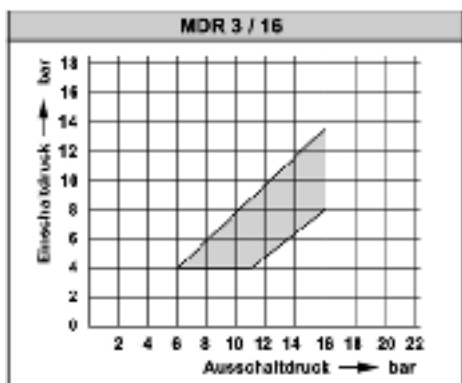
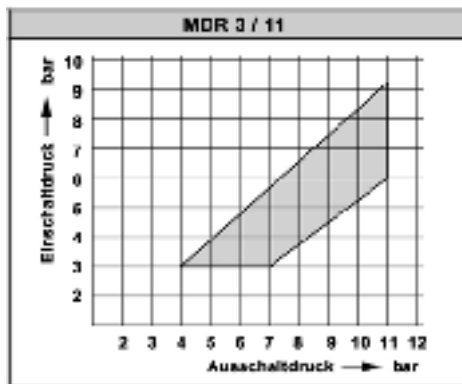
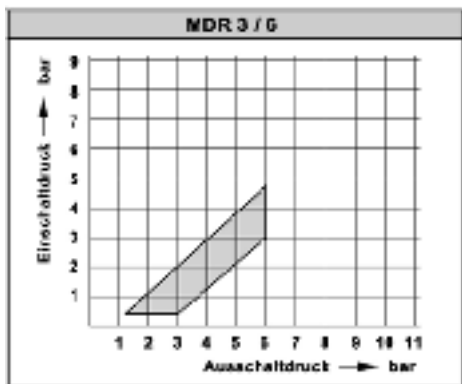

Einerschaltdruck  
Cut-in pressure  
Pression de disparo inferior  
Pression de déclenchement  
Pressione di attacco

Ausschaltdruck  
Cut-out pressure  
Pression de disparo superior  
Pression déclenchement  
Pressione di distacco

\*MDR3 EA in Position / I Auto  
MDR 3 EA in position / I Auto  
MDR 3 EA en posición / I Auto  
MDR 3 EA dans position / I Auto  
MDR 3 EA in posizione / I Auto

**ANBAU DER MODULE / MOUNTING ADD-ON MODULES / MONTAJE DE LOS MODULES /  
MONTAGE DES MODULES / MONTAGIO DEI MODULI**

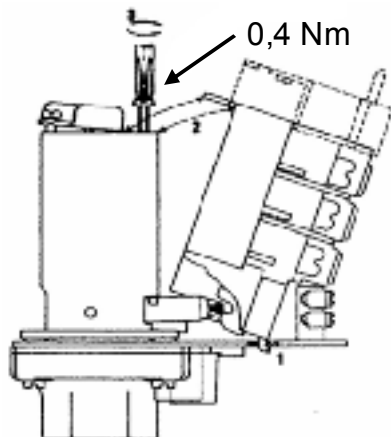

1. - Nase wie im Piktogramm schräg einsetzen
2. - Modul nach hinten kippen
3. - Befestigungsschrauben festdrehen

Wechsel bereits montierter Module:  
in umgekehrter Reihenfolge verfahren

1. - Insertar el tetón como en la pictografía
2. - Presionar hacia atrás
3. - Apretar tornillos

Cambiar módulos ya montados: proceder al inverso

1. - Inserire obliquamente il beccuccio come da schema illustrativo
2. - Raddrizzare il modulo
3. - Serrare le viti di fissaggio

Sostituzione moduli: procedere in senso inverso

Haubenbefestigung / Cover fastening / Fijación de la tapa / Fixation par coiffe / Fissaggio coperchio: 1 Nm /

Anbau der Module / Add-on Modules / Módulos Montables / Modules complémentaires / I Moduli:  
s. Katalog / see catalogue / ver catálogo / voyez notre catalogue / vedere catalogo

1. - Insert catch as shown
2. - Push the module backwards
3. - Tighten screws

Changing matented modules: proceed in reverse

1. - Insérer le tetón en oblique
2. - Pousser le module vers l'arrière
3. - Serrer les vis de fixation

Pour remplacer un module: fait l'opération inverse

**Kurzschlußschutzeinrichtung für MDR 3 / Protection against short-circuit for MDR 3 / Protección contra corto circuito para MDR 3 / Protection contre court-circuit pour MDR 3 / Protezione contro corto circuito per MDR 3 Iq ≤ 50kA**

Type / Tipo	Koordinat Type "1"	Koordinat Type "2"
	Co-ordination Type "1"	Co-ordination Type "2"
	Coordinación Tipo "1"	Coordinación Tipo "2"
	Coordination Type "1"	Coordination Type "2"
	Coordinamento Tipo "1"	Coordinamento Tipo "2"
Überstromrelais	max. Sich. gl	oder
Overload relais	max. Fuse (slow)	or
Relé térmico	max. Fusible (retardado)	o
Relais disjoncteur	max. Fusible (retardé)	ou
Relé termico	max. Fusible (ritardato)	o
	400 V	690 V
SK-R3/1,0	80 A	63 A
SK-R3/1,6	80 A	63 A
SK-R3/2,5	80 A	63 A
SK-R3/4,0	80 A	63 A
SK-R3 (H)6.3 . 24	80 A	63 A
SK-R3 (H)/SK-R3(H-S)	80 A	63 A

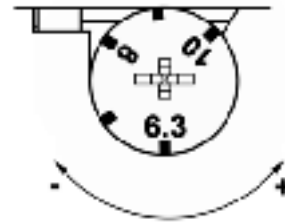

Motorenstrom am Excenter des SK-R3 Überstromrelais wie abgebildet einstellen.

Use dial to adjust the overload relay SK-R3 to the rated motor current as shown

Usar la excéntrica para ajustar el relé térmico SK-R3 a la corriente nominal del motor como en la pictografía

Déplacé l'excentrique du thermique SK-R3 a la valeur du courant nominal du moteur comme indiqué

Torare la corrente nominale del motore sul relais termico SK-R3 agendo sull'eccentrico come indicato

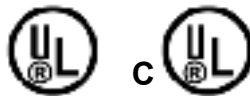

Horsepower Ratings und Short Cimuit Proteejan acc. to UL 508										
Conrad Block	110 - 120 V		220 - 240 V		440 - 480 V		550 - 600 V		Short Circuit Protection	
Type	1-ph	3-ph	1-ph	3-ph	1-ph	3-ph	1-ph	3-ph	max. V	max. Fuse
SK-R3/1	-	-	-	-	-	½	-	½	600	15 A
SK-R3/1,6	-	-	1/10	1/10	-	3/4	-	1	600	15 A
Sk-R3/2	-	-	1/6	1/2	1/2	1	1/2	1 1/2	600	15 A
SK-R3/4	1/10	1/2	1/10	1	1	2	1 1/2	3	600	15 A
SK-R3/6,3	1/4	3/4	1/2	1 1/2	2	3	2	5	600	25 A
Sk-R3/10	1/2	1	1 1/2	3	3	5	3	7 1/2	600	40 A
SK-R3/16	1	2	2	5	5	10	7 1/2	10	600	60 A
SK-R3/20	1 1/2	3	3	-	-	-	10	-	600	80 A
SK-R3/24	2	-	-	7 1/2	7 1/2	-	10	-	600	100 A
SK-R3H16	1	2	2	5	5	10	7 1/2	10	600	60 A
SK-R3H/20	1 1/2	3	3	-	-	-	10	15	600	80 A
SK-R3H/24	2	-	-	7 1/2	7 1/2	15	10	20	600	100 A
SK-R3/30/2	2	-	5	-	-	-	-	-	240	110 A

Max. Operating pressure	
MDR 3 / 6	90 psi / 600 kPa
MDR 3 / 11	160 psi / 1100 kPa
MDR 3 / 16	230 psi / 1600 kPa
MDR 3 / 25	360 psi / 2500 kPa
MDR 3 / 35	510 psi / 3500 kPa

\* see pressure diagrams

1. Suitable for use on a circuit capable of delivering not more than 5 kA rms symmetrical Amperes, 600 Volts maximum ( 240 Volts for SK-R3/30/2 ) when protected by nontime delay fuses as noted in the table above.
2. Suitable for group fusing of 5 kA rms symmetrical Amperes 600 V, 3-ph maximum ( SK-R3/30/2 240V. 1-ph max. ) when protected by time delay fuses rated max. 100 A.
3. Use 75° copper wire AWG 10 -AWG 14
3. AC Motor Load
5. Break all lines
6. Trip current is 125% of dial setting

30.310.93.001 02.11.2005



**Condor Pressure Control GmbH**

Warendorfer Straße 47 – 51  
D-59320 Ennigerloh

Telefon: +49 (0) 25 87 / 89 – 0  
Telefax: +49 (0) 25 87 / 89 - 140

info@condor-cpc.com  
www.condor-cpc.com